

HANDBOOK

FM SERIES

3000W POWER COMBINER

***READ THIS BEFORE ATTEMPTING
TO COMBINE 3 FM1000s***

IPTEK

Contents

Theory of operation.....	2
Specifications	3
Safety Notice	4
Rear Panel Layout	5
Installation	8
Schematic Chassis	12

MOD RECORD
FIRST PRINT.....FEB 2005

Theory of operation

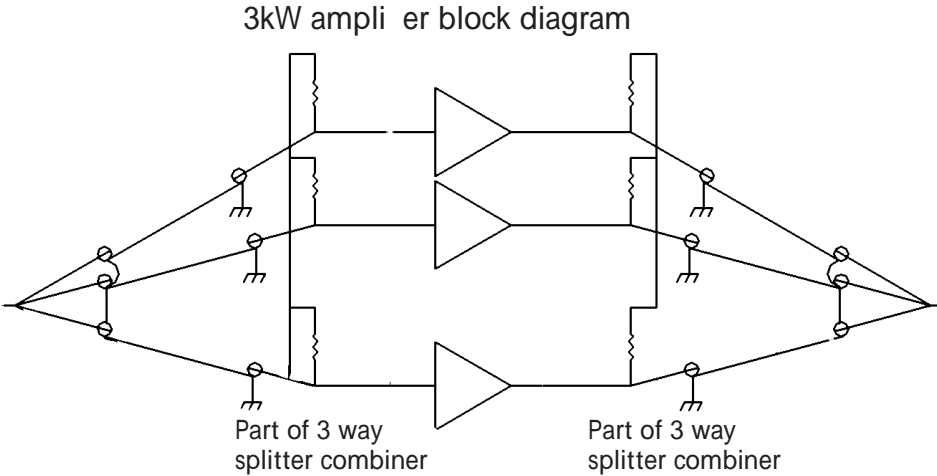

The 3kW power amplifier system consists of 3 FM1000 power amplifiers and a combiner/splitter. Each FM1000 is a self-contained unit capable of producing up to 1100W over the frequency range 88 to 108 MHz. When not combined they operate normally and can be used in any other application as a driver or directly on air.

The combiner splitter provides a 3 way in phase splitter (WILKINSON) and a 3 way in phase combiner (WILKINSON). Both combiner and splitter provide port to port isolation enabling the system to function with one or more of the FM1000s disabled.

In the system each FM1000 is connected to the other via a DB25 ribbon cable. This cable also provides 24V to the combiner fan. Power setting via the front panel or remote raise lower switch are transferred to all the FM1000s maintaining the same power output from all the units.

Metering on the accessory cable is combined so the total current and Voltage is a sum of all the amplifiers.

Specifications

Parameter	Characteristics
General	
Frequency Range	87.5 to 108MHz
Insertion Loss	0.3dB Max.
Input and output RF Connecters	Type N Female
Main RF output Connector	7/16 DIM Female
Environmental	
Temperature	-10 to 35 degrees C
Elevation	10,000 ft ASL Max.
Cabinet	
Width	19.0in panel drilled to EIA RETMA hole spacing
Height	5.25in three EIA RETMA units
Depth	12 in
Weight	20lbs
Packaged	25X19X11

Safety

BEFORE APPLYING POWER

GROUND THE POWER COMBINER

To minimize shock hazard, the power combiner chassis must be connected to an electrical ground. This is normally done via the power amplifier which must be connected to the ac power mains through a three-conductor power cable, with the third wire firmly connected to an electrical ground (safety ground) at the power outlet. Any interruption of the protective (grounding) conductor or disconnection of the protective earth terminal will cause a potential shock hazard that could result in personal injury. If the power combiner is to be energized by any other source be certain the that chassis is connected to a separate safety ground.

DO NOT OPERATE IN AN EXPLOSIVE ATMOSPHERE

Do not operate the power amplifier in the presence of flammable gases or fumes.

DO NOT REMOVE THE POWER COMBINER COVER

Operating personnel must not remove the power combiner cover. Component replacement and internal adjustments must be made only by qualified service personnel.

Output connector

The type N output connector carries dangerously high RF voltages which present a shock and burn hazard. **NEVER** operate this combiner with out the out put connector properly terminated in either an adequately rated load or antenna.

Rear panel layout

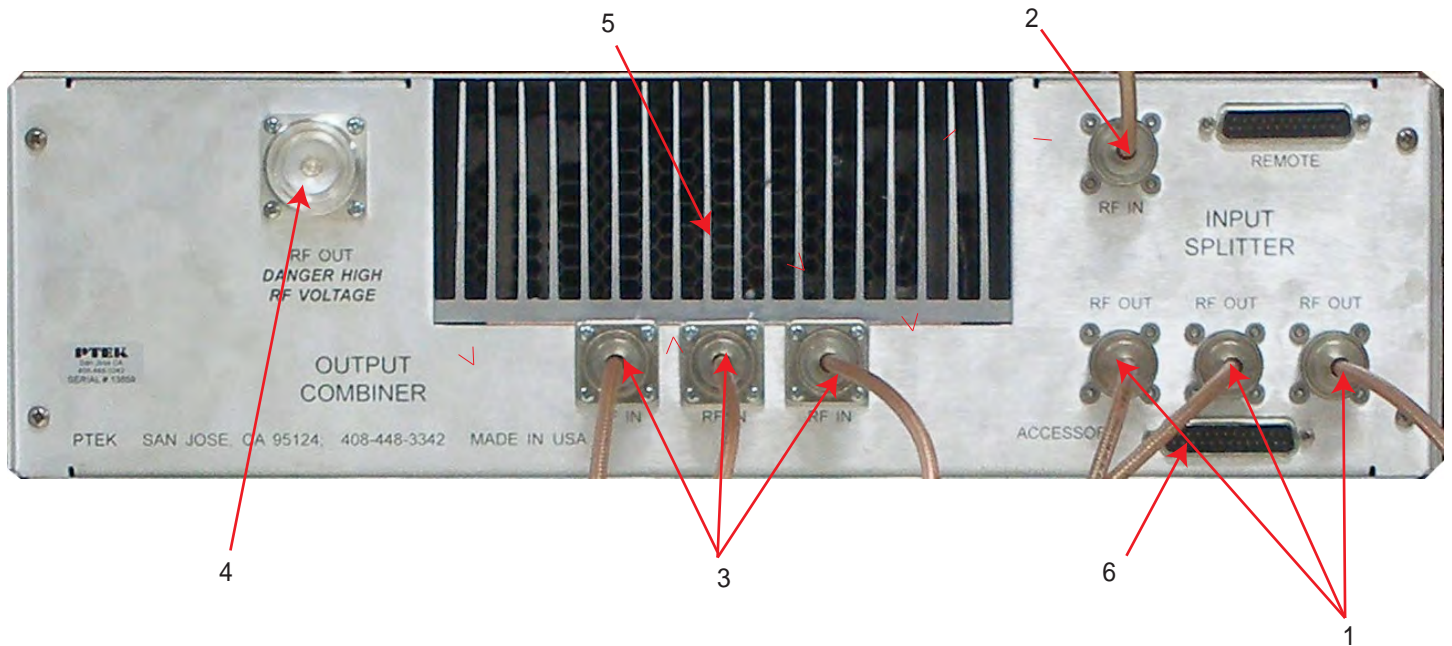

key	Element	Description
1	OUT	Outputs from input splitter, drives power amplifiers
2	IN (FROM EXCITER)	Main Drive from exciter
3	IN	Outputs from power amplifiers
4	OUT (TO ANTENNA)	Main RF Output 2kW Danger High RF Voltage
5	Cooling air exhaust	
6	Accessory	Used to supply internal 24V fan

Installation-Hardware

(For optional rack sides)

Refer to the figure left and tables below for the following description. The installer will need a normal set of shop tools to perform the installation procedure.

Step	Procedure
1	Install the right and left Stationary Section into the installation rack with the screws and hardware provided. The amplifier cabinet is 24 inches, it may be necessary to also use an extension to the Stationary Section depending on installation rack dimensions.
2	Install the right and left Chassis Section to the FM Broadcast Amplifier cabinet in the 8-32 holes using the screws provided. IMPORTANT: The amplifier weighs 36 kg (80 lbs) and will require two individuals to pick up and install the amplifier in the installation rack.
3	Install the amplifier cabinet into the Stationary Sliders.
4	Install four user provided #10 screws through the front panel holes into the installation rack
5	Repeat for the additional FM500 and combiner. Use the order below

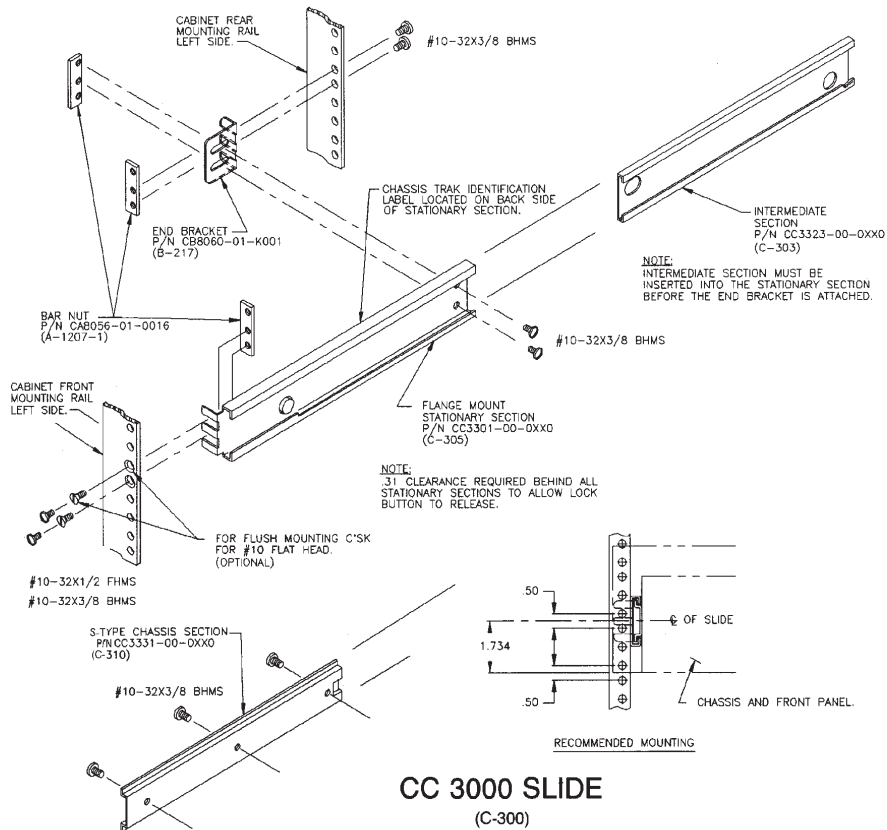

Rack Positions

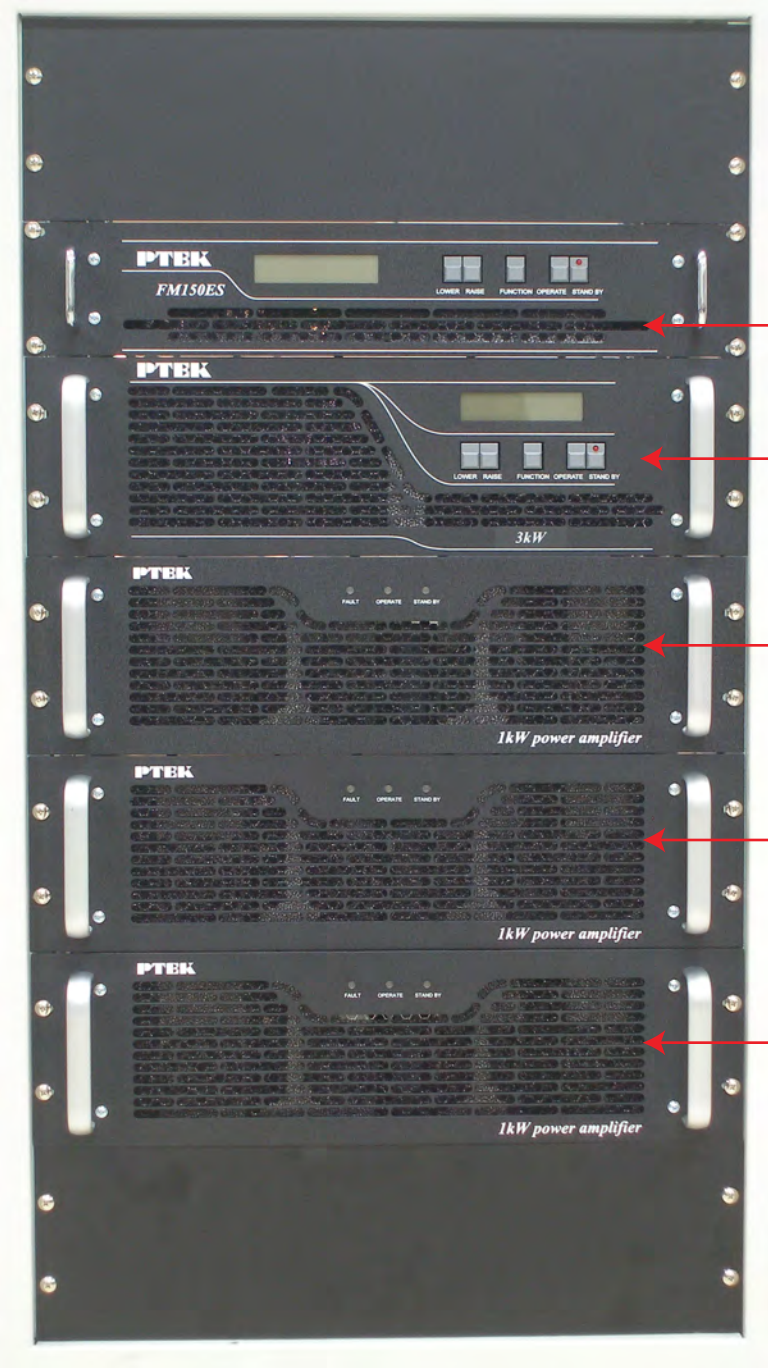

150W Exciter

3kW Combiner

1000W Power Amplifier

1000W Power Amplifier

1000W Power Amplifier

Installation-Electrical

Refer to the Table below for the following description. The installer should assure the ac line voltage is turned OFF before performing this procedure. The electrical connections are installed at the FM Broadcast Amplifier rear panel.

Step	Procedure
1	Connect the RF cables as shown below. All RF Cables are the same length and can be interchanged.
2	Connect exciter output to Input.
3	Connect the load RF line to OUTPUT COMBINER OUT connector.
4	Connect the ribbon cable
6	Connect the ac line power to the ac line in connectors.
7	Optional. Connect the ac line to exciter or other user application to the switched ac line output (150W max.). The user application's performance should be verified before making this connection.
8	Optional. Connect the remote site metering, to the spare 25w "D" connector

D-connector pin out

1	Forward Power DC indication $2.4V=600W$
2	Final Voltage DC indication $V=V_{supply}/10$
8	Lower: Ground to lower Output Power
10	Serial data, used when 2 or more amplifiers are combined
13	Remote off, grounding this momentarily switches the amplifier to standby
14	Reverse power indication $2.4V=60W$
5,18,6,19	24V Output (Fan supply on combiner)
20	Raise: Ground to raise the output power
25	Remote on, grounding this momentarily switches the amplifier to operate
11,12,23,24	Ground

RF Cabling

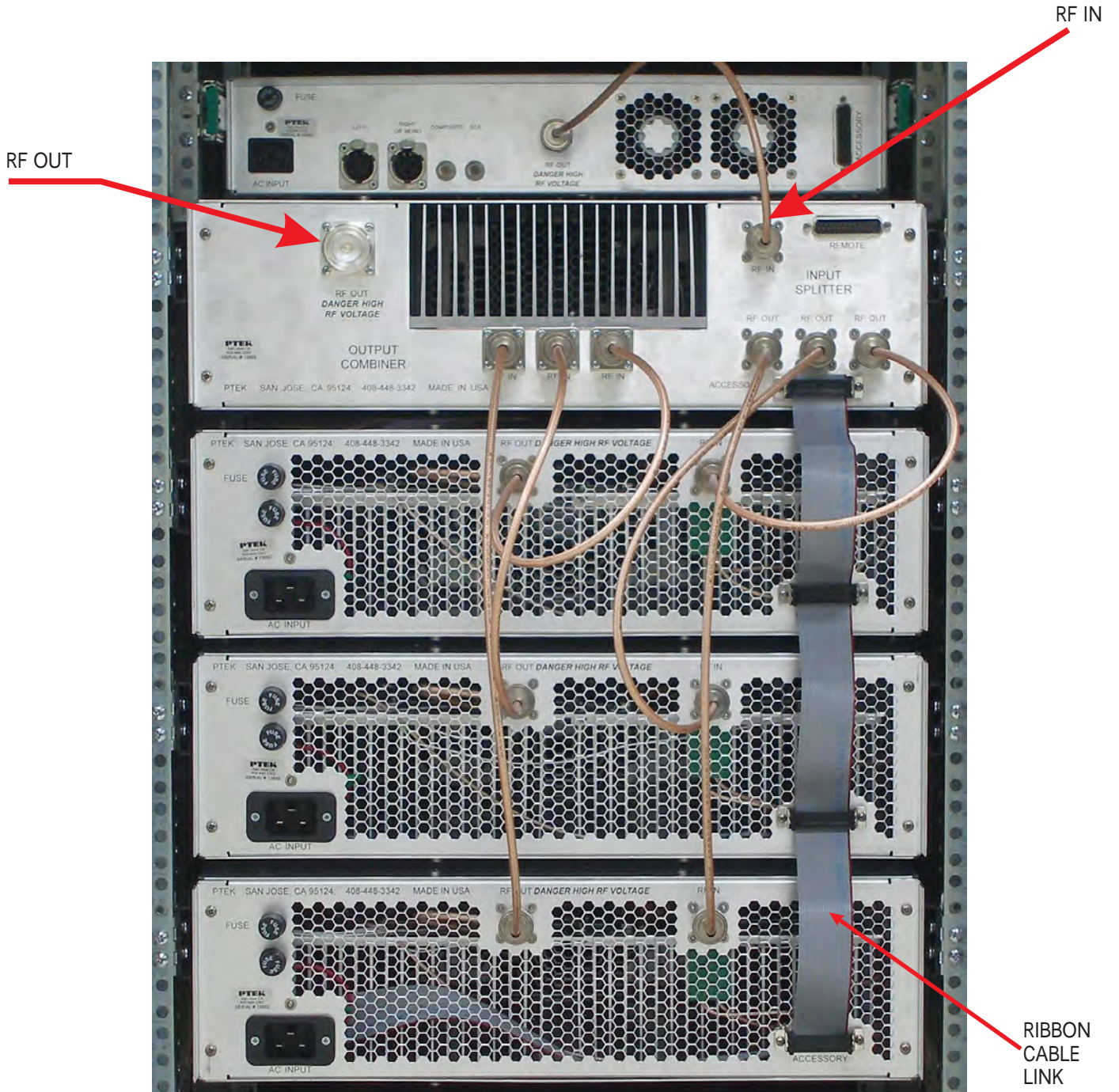

Turn-On Checkout

Refer to the Table below for the following procedure. Initially, the RF source or exciter should be powered up from an independent ac line source (not the switched ac line on the FM Broadcast Amplifier) and its RF power level output set to **50W**. Its ac line then can be connect to the switched ac line on the FM Broadcast Amplifier.

Step	Action	Verification
1	Switch the RF out to a dummy load. (Optional) or a matched antenna	
2	With the Operate Switch in the operate position, Enable AC line power.	REMOTE OFF indicator is out.
3	Depress the raise/lower switch in the lower position and hold for 30 seconds.	First time switch on sets the power to a low value. This need not be done once a safe operating power level has been established
4	Enable the exciter.	
5	Raise or lower the output power to the level required 250~3000W. (you may have to increase the drive level to do this)	Check that the indicated power shows the desired operating level. Check and note the supply current and voltage. Check that the drive power is in the range 50 to 150W

Schematic Chassis.

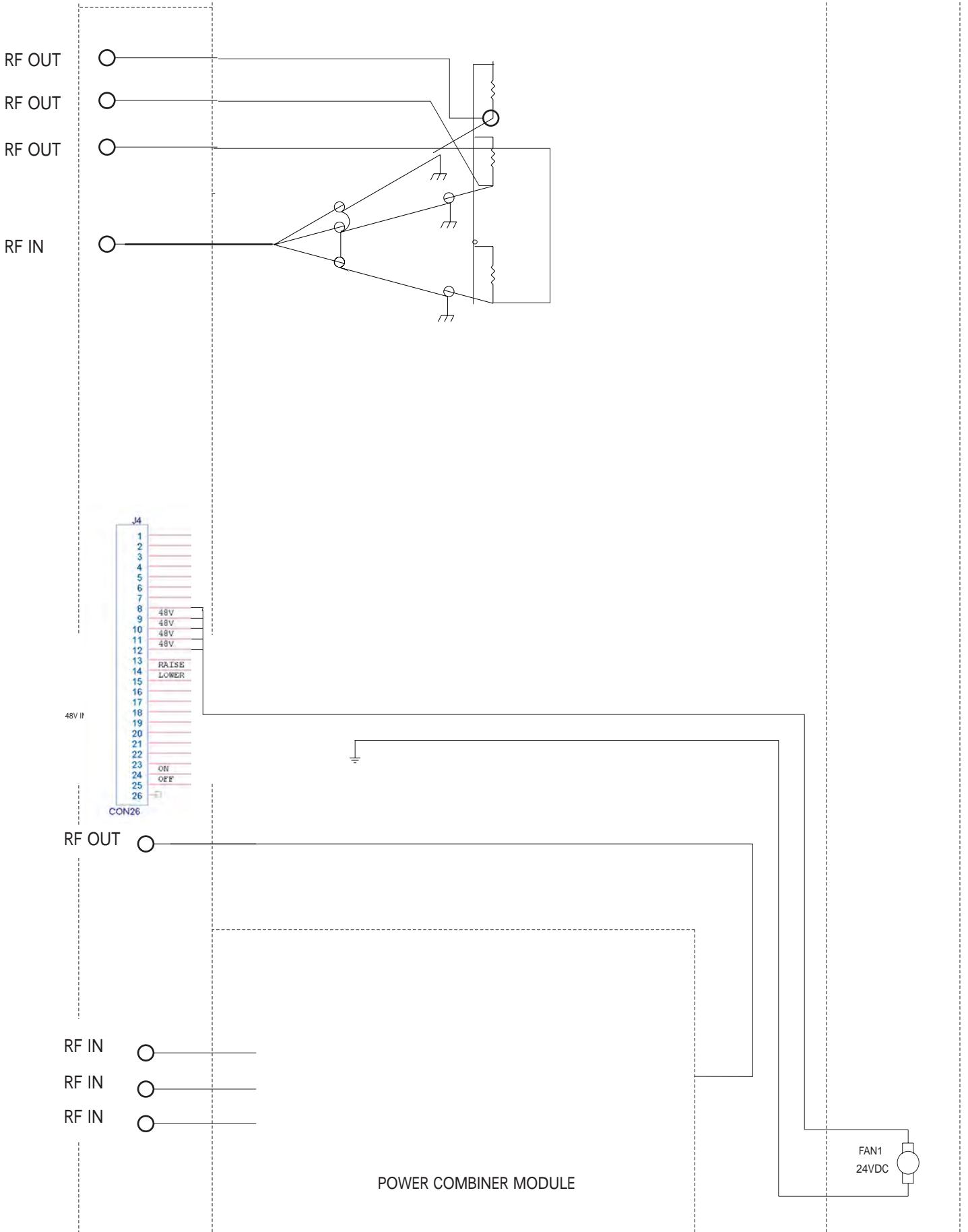

PTEK
1723 Little Orchard Street # D
San Jose CA 95125
408 448 3342 FAX 408 448 5951
Printed in USA